



Instruction Manual

20V Cordless Chainsaw

PLU-156438



Before any use, refer to the corresponding paragraph in the present manual.

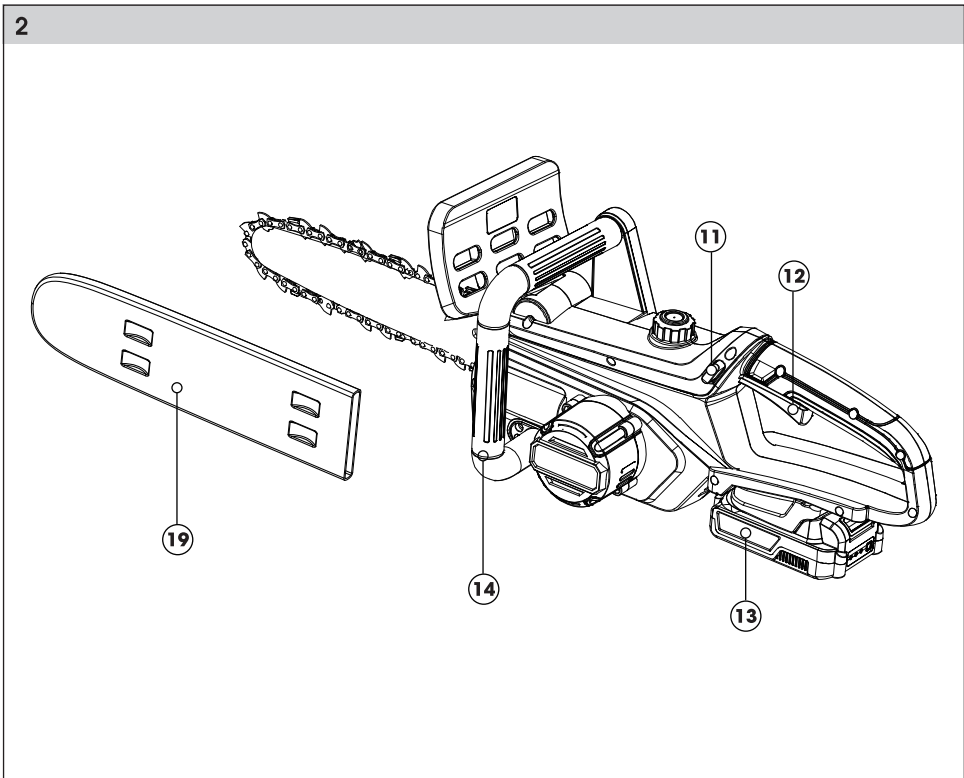
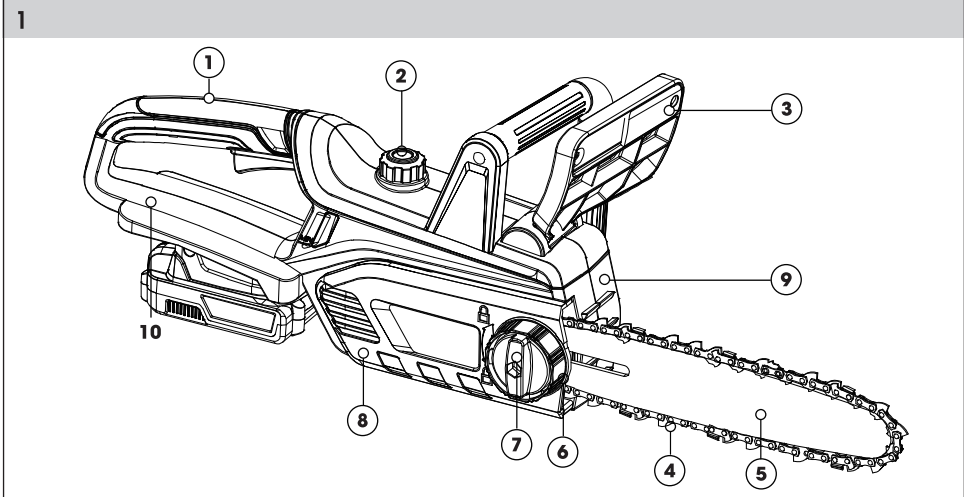

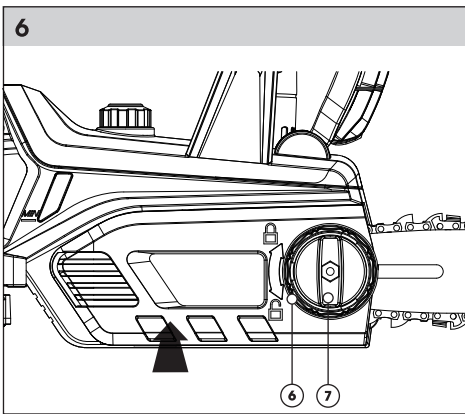
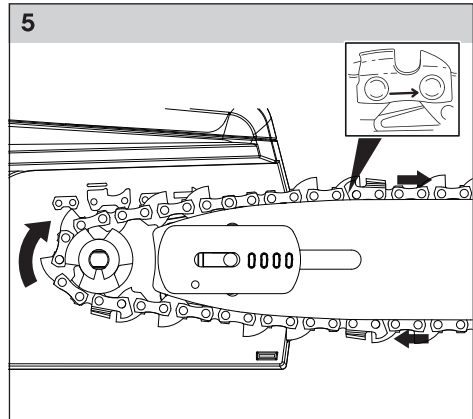
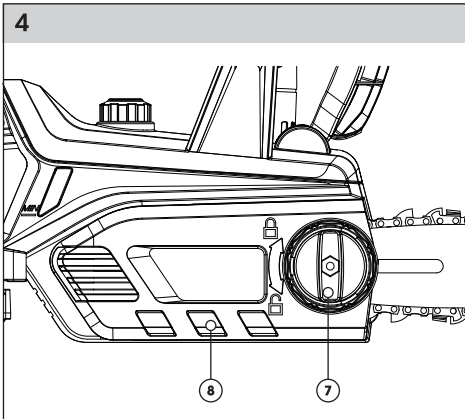
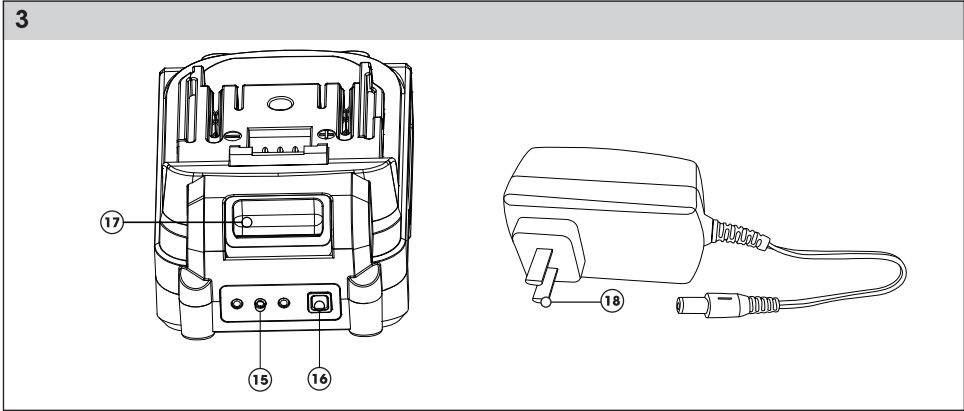

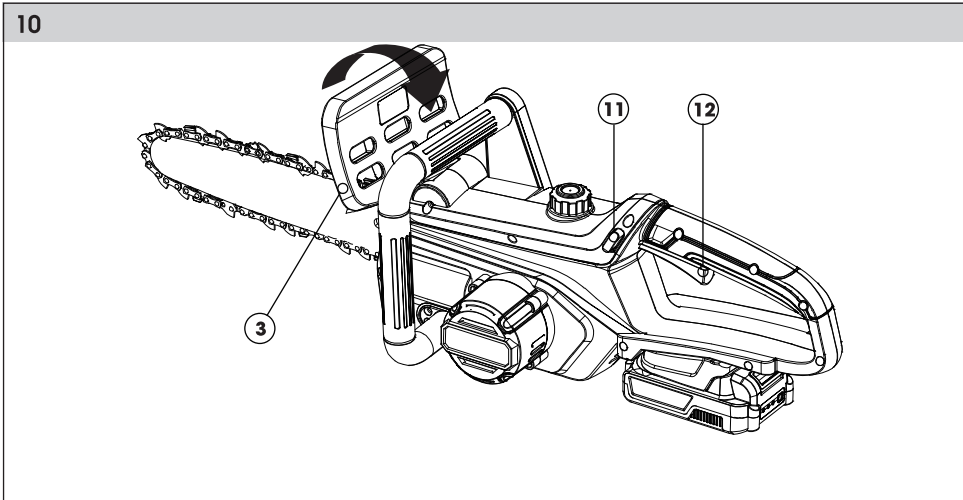
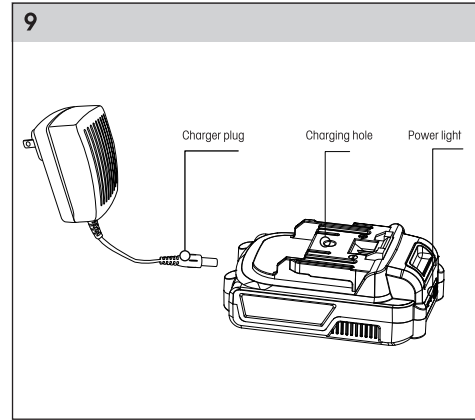
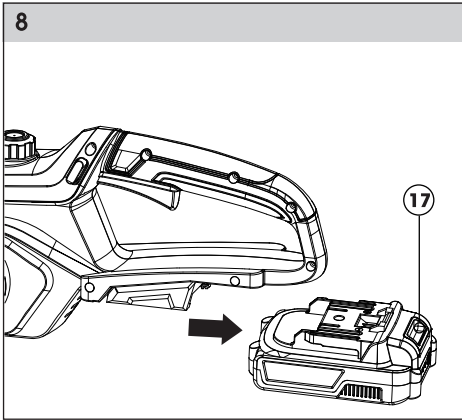

20 V Chain Saw

USER'S MANUAL

Thank you for purchasing this Chain Saw. Before you start using it, please carefully read this user's manual and save it for possible future use.

TABLE OF CONTENTS

1. SAFETY INSTRUCTIONS	7
2. SYMBOLS	8
3. MACHINE DESCRIPTION AND PACKAGE CONTENT.....	10
4. SAFETY INSTRUCTIONS.....	11
5. ASSEMBLY	13
6. OPERATION.....	15
7. CLEANING AND MAINTENANCE	21
8. STORAGE.....	23
9. TECHNICAL DATA.....	23
10. DISPOSAL.....	24

1. SAFETY INSTRUCTIONS

WARNING!

Carefully read the instruction manual before use.

Important safety warnings

- ✿ Unpack the product carefully and be sure not to throw away any part of the package before having found all components of the product.
- ✿ Keep the product in a dry place out of reach of children.
- ✿ Read all cautions and instructions. The failure to adhere to warning cautions and instructions may result in an accident, fire and/or a serious injury.

Packaging

The product is placed in a package preventing damage during transport. This package is a raw material therefore it can be handed-over for recycling.

Instructions for use

Before beginning to work with the machine, read the following safety rules and instructions for use. Familiarize with operating elements and the proper use of the device. Keep the manual in a safe place for future reference. We recommend keeping the original package including the inner packaging materials, cash voucher and guarantee card for a period of warranty at minimum. For a case of transportation, pack the machine into the original box from the manufacturer, thus ensuring a maximum protection of the product during a possible transport (e.g. moving or sending into a service station).

 **Note:** If you hand the machine over to next persons, hand it over together with the manual. Adherence to the attached instructions for use is a precondition for the proper use of the machine. The operation manual includes also instructions for operation, maintenance and repairs.

The manufacturer does not take any responsibility for accidents or damages resulting from the failure to adhere to this manual.

2. SYMBOLS



Be careful when handling the device!
Observe all safety instructions in the instructions for use!



Read and observe the operating instructions before commissioning.



Do not expose the machine to moisture.



Area with a danger of kickback.



Always hold the device firmly in both hands.

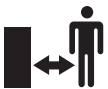

Always maintain a sufficiently safe distance.

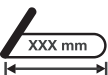

Length of the saw rail



Eye protection: wrap-around goggles/
protective visor on the helmet



Ear protection: earplugs/ear muffs



Head protection: safety helmet with visor



Foot protection: safety shoes with gripping
soles, steel caps and leg protection



Hand protection: protective chainsaw
gloves



Clothing: safety overalls (cut-proof),
Safety jacket (cut-proof)

3. MACHINE DESCRIPTION AND PACKAGE CONTENT

Machine Description (see Fig. 1)

2. Fill opening for chain oil (tank cover)
3. Front hand guard (trigger for chain brake)
4. Saw chain
5. Saw rail
6. Chain tensioning screw
7. Quick locking device (for saw rail)
8. Chain wheel guard
9. Sight glass for oil level
10. Rear hand guard

Machine Description (see Fig. 2)

11. Safety lock
12. On-Off switch
13. Battery pack
14. Front handle
19. Protective cover

Machine Description (see Fig. 3)

15. Display for remaining capacity
16. Push button for capacity display
17. Locking button
18. Battery charger

Package Content

Remove the machine carefully from the packaging and check the completeness of the following parts:

- * Chain saw
- * Bar
- * Bar cover
- * Chain
- * Instructions for use
- * Warranty card

4. SAFETY INSTRUCTIONS

⚠ ATTENTION!

Familiarize yourself with all the warning and safety instructions and with the tool operating instructions.

⚠ ATTENTION!

Failure to adhere to warning or safety instructions may result in electric shock, fire and/or serious injury.

⚠ ATTENTION!

Keep all the warning and safety instructions in a practical place for future reference.

 **Note:** The term “power tool” in all the warning instructions specified hereafter means (corded) power tool.

Work area safety

- ✿ Keep work area clean and well lit. Cluttered or dark areas at the workplace invite accidents.
- ✿ Do not operate power tools in explosive atmospheres, such as in the presence of flammable liquids, gases or dust. Power tools create sparks which may ignite the dust or fumes.
- ✿ Keep children and bystanders away while operating a power tool. Distractions can cause you to lose control over the tool.

Electrical Safety For Corded Power Tool

- ✿ Power tool plugs must match the mains outlet. Never modify the plug in any way. Do not use any adapter plugs with earthed (grounded) power tools. Unmodified plugs and matching outlets will reduce the risk of electric shock.
- ✿ Avoid body contact with earthed or grounded surfaces, such as pipes, radiators, ranges and refrigerators. There is an increased risk of electric shock if your body is earthed or grounded. Do not expose power tools to rain or wet conditions. Water entering a power tool will increase the risk of electric shock.
- ✿ Do not abuse the cord. Never use the cord for carrying, pulling or unplugging the power tool. Keep cord away from heat, oil, sharp edges or moving parts. Damaged or entangled cords increase the risk of electric shock.
- ✿ When operating a power tool outdoors, use an extension cord suitable for outdoor use. Use of a cord suitable for outdoor use reduces the risk of electric shock.
- ✿ If operating a power tool in a damp location is unavoidable, use a residual current device (RCD) protected supply. Use of residual current device (RCD) reduces the risk of electric shock.

 **Note:** The term “residual current device” (RCD) may be substituted by the term “ground fault circuit interrupter” (GFCI) or “earth leakage circuit breaker” (ELCB).

Personal safety

- ✿ Stay alert, watch what you are doing and use common sense when operating a power tool. Do not use a power tool while you are tired or under the influence of drugs, alcohol or medication. A moment of inattention while operating power tools may result in serious personal injury.
- ✿ Use personal means of protection. Always wear eye protection. Safety equipment such as dust mask, non-skid safety shoes, hard hat, or hearing protection used in conformity with the working conditions will reduce personal injuries
- ✿ Avoid accidental starting. Ensure the switch is in the off-position before connecting the battery, storing or carrying the power tool. Carrying power tools with your finger on the switch or plugging in power tools that have the switch on invites accidents.

- ✿ Remove any adjusting tools or wrenches before turning the power tool on. An adjusting tool or wrench left attached to a rotating part of the power tool may result in personal injury.
- ✿ Do not overreach. Keep proper footing and balance at all times. This enables better control of the power tool in unexpected situations.
- ✿ Dress properly. Do not wear loose clothing or jewellery. Keep your hair, clothing and gloves away from moving parts. Loose clothes, jewellery or long hair can be caught in moving parts. If devices are provided for the connection of dust extraction and collection facilities, ensure these are connected and properly used. Use of these devices can reduce dust-related hazards.

Power tool use and maintenance

- ✿ Do not force the power tool. Use only the correct power tool for your application. The correct power tool will do the job better and safer at the rate for which it was designed.
- ✿ Do not use the power tool if the switch does not turn it on and off. Any power tool that cannot be controlled with the switch is dangerous and must be repaired.
- ✿ For corded power tools, unplug the power cord from the mains outlet before making any adjustments, changing accessories, or storing power tools. Such preventative safety measures reduce the risk of starting the power tool accidentally.
- ✿ Store idle power tools out of the reach of children and do not allow persons unfamiliar with the power tool or these instructions to operate the power tool. Power tools are dangerous in the hands of untrained users.
- ✿ Maintain power tools. Check for misalignment or binding of moving parts, pay particular attention to cracks, breakage of parts and any other condition that may affect the power tool's operation. If damaged, have the power tool repaired before use. Many accidents are caused by poorly maintained power tools.
- ✿ Keep cutting tools sharp and clean. Properly maintained cutting tools with sharp cutting edges are less likely to bind and are easier to control.
- ✿ Use the power tool, accessories and tool bits etc., in accordance with these instructions and in the manner intended for the particular type of power tool, taking into account the given working conditions and the work to be performed. Use of the power tool for operations other than those for which the power tool is intended could result in hazardous situations.

Service

- ✿ Have your power tool serviced by a qualified repair person using only original replacement parts. This will ensure that the safety of the power tool is maintained.

Storage

- ✿ only carry and store the tool with the scabbard fitted
- ✿ carefully clean the tool and carry out adequate maintenance before storing
- ✿ before carrying, secure the tool against fuel leakage, damage or injury

Use and treatment of the cordless tool

- ✿ Only charge the batteries with chargers recommended by the manufacturer. A charger that is suitable for a certain type of battery creates a fire hazard when used with other batteries.
- ✿ Only use the batteries provided for this purpose in the power tools. The use of other batteries can lead to injuries and fire hazards.
- ✿ Keep the unused battery away from paper clips, coins, keys, nails, screws or other small metal objects that could cause the contacts to be bridged. A short circuit between the battery contacts can result in burns or fire.
- ✿ If used incorrectly, liquid can leak out of the battery. Avoid contact with it. In case of accidental contact, rinse with water. If the liquid gets into your eyes, get additional medical help. Leaking battery fluid can cause skin irritation or burns.

5. ASSEMBLY

⚠ DANGER! Risk of injury during operation! Improperly mounted parts can cause severe and even fatal injuries when using the device!

This device may only be commissioned if all parts are mounted completely and tightly and no part is damaged!

- ✿ Therefore, read the whole chapter before you assemble the parts!
- ✿ Assemble the parts carefully and completely.
- ✿ Use tools when their use is suggested.

⚠ CAUTION! Risk of injuries due to cuts!

The teeth of the saw chain are very sharp! Protective gloves must be worn for all work on the chain.

⚠ WARNING!

Risk of injury! An improperly mounted saw chain causes uncontrolled cutting behavior of the device! When assembling the chain, heed the prescribed running direction!

Assembling the saw rail and saw chain

- ✿ Release the chain brake (3) (move the hand guard back and engage it).

▶ (see Fig. 4)

- ✿ Unlock, undo the quick locking device (7) and remove the chain wheel guard (8).

▶ (see Fig. 5)

 **Note:** When attaching the chain, heed the correct position of the guide groove (saw rail).

- ✿ Place the sawing chain onto the chain wheel. Pay attention to the chain's correct direction of rotation:

The direction in which the arrow points on the chain must match the direction marked on the chain wheel.

- ✿ Attach the saw rail and push it towards the chain wheel.
- ✿ Insert the sawing chain into the guiding groove of the saw rail.
- ✿ Route the sawing chain around the saw rail. Ensure the correct location inside the guiding groove.

▶ (see Fig. 6)

- ✿ Attach the chain wheel cover. The chain dowel pin must engage in the hole of the saw rail.
- ✿ Now gently tighten the quick locking device (7).

Tightening the chain

▶ (see Fig. 6)

- ✿ Slightly lift the tip of the saw rail.
- ✿ Check if the sawing chain runs smoothly by turning it manually.
- ✿ Turn the tensioning screw (6) until the chain lies on the underside of the saw rail.
- ✿ Tighten and lock quick locking device (7).

Letting the saw chain run in

During the run-in time, re-tension the saw chain and rail after a maximum of 5 cuts.

Checking the tensioning of the saw chain

The saw chain is tensioned correctly if it lies close against the underside of the saw rail and can be moved easily by hand.

Readjust tension of the saw chain when necessary (▶ Re-tensioning the saw chain –p. 21).

Checking the chain lubrication

The device may not be used without sufficient chain lubrication. Insufficient lubrication reduces the service life of the device.

- ✿ Check the oil quantity in the tank.
- ✿ Start the device.
- ✿ Hold the running saw chain approx. 15 cm over a suitable surface for a time (15 s).

If there is sufficient chain lubrication, the oil spraying off of the saw chain will form a slight trail.

Checking the chain brake

The chain brake ensures immediate blocking of the saw chain in case of a kickback. Before beginning work with the device, it must be checked to ensure that it is functioning correctly.

- ✿ Set device on the ground.
- ✿ Start the device.
- ✿ Tip the hand guard forwards. The chain must stop immediately.
- ✿ If the chain brake is not working correctly, contact a service partner immediately.

Filling up saw chain oil

► (see Fig. 7)

Note: Environmental damage!

Since the saw chain oil can penetrate the environment during operation, biologically-degradable special vegetable-based saw chain oils should be used.

- ✿ Lay device securely with the tank cover (2) upwards.
- ✿ Before opening, clean the tank cover and the filler neck if necessary.
- ✿ Open flap and remove tank cover.
- ✿ Carefully fill up the saw chain oil. Do not spill!
- ✿ Read the oil level at the inspection glass (9). The oil stand must be placed between **(MIN)** and **(MAX)**.
- ✿ Attach tank cover and close flap.
- ✿ If you have spilled.

6. OPERATION

Safety equipment

The device has several pieces of safety equipment which reduce the risk of injury when working:

Claw stop

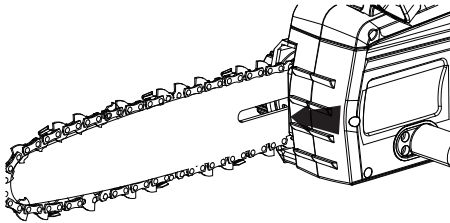

The claw stop enables the motor block to be secured to the wood when using pull saws.

Uncontrolled kickback of the saw is thus made more difficult. The process also exerts pressure on the saw chain thanks to the generated leverage.

Chain catcher

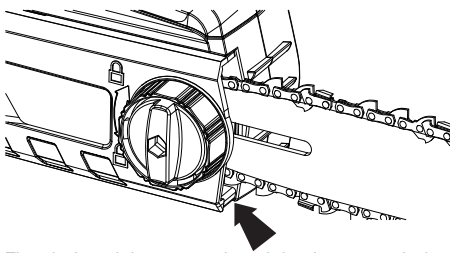

The chain catcher serves to catch a torn saw chain or one which has jumped out of the guide. Through regular maintenance of the saw rail and correct and regular tensioning of the saw chain, accidents of this type can be prevented.

Rear hand guard

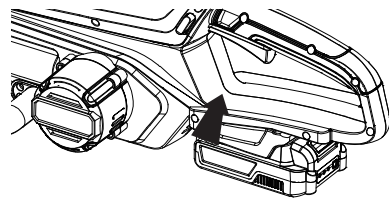

The rear hand guard serves to protect the hand against a jumped chain and disturbing branches and twigs.

Charging the battery pack

⚠ WARNING! Risk of injury!

Comply with all safety instructions when handling rechargeable devices.

📖 Note: Risk of damage to the unit! Due to the high operating current, the unit must only be operated with batteries with Replacement batteries are not suitable for operation with this unit.

📖 Note: Risk of damage to the unit! Do not allow the battery pack to deep discharge.

📖 Note: If the battery is fully loaded, the charger automatically switches over to the maintenance charge function.

The battery can thus remain in the charger permanently.

The battery pack must be charged prior to the first start-up (charging time: ► Technical data – p. 23).

- ✿ Press in the locking button (17) and remove the battery from the device.
- ✿ Insert the battery pack into the charger.
- ✿ Plug the charger into the power supply.

Checking the remaining capacity of the battery

- ✿ Press the button (16).

The remaining capacity of the battery is displayed by the control lights (15).

Check before starting!

⚠ DANGER! Risk of injury! The device must only be put into operation if no faults are found. If any part of the device is defective, it must be replaced before the next use.

Check the safety equipment and the safe condition of the device.

- ✿ Check all parts for their firm fit.
- ✿ Check whether there is any leakage.
- ✿ Check whether there are visible defects: broken parts, cracks, etc.
- ✿ Check the device for correct chain tensioning.
- ✿ Check the function of the chain brake.

Switching on/off

► (see Fig. 10)

- ✿ Hold the device firm with both hands.
- ✿ The hand guard (3) must be folded towards the back.
- ✿ Switching on: Press switch-on safety lock (11) and On/Off switch (12) simultaneously.
- ✿ Switching off: Release On-Off switch (12).

Use

Before use, familiarize yourself sufficiently with the sawing technique for chain saws.

You will find information about this in the trade literature. We recommend that you attend suitable training sessions. The notes here serve only as a complement!

Correct posture

⚠ DANGER! Risk of injury! Never work on unstable sub-surfaces!

- Never work above shoulder height!
- Never work while standing on a ladder!
- Do not work bent too far forward!
- Only use the device under favourable weather and site conditions!

- ☼ Stand with both legs securely on the ground.
- ☼ Heed obstacles in the work area.
- ☼ While you are working, always hold the device fast with both hands!

Hold the device:

- ☼ with the left hand on the front handle.
- ☼ with the right hand on the rear handle.
- ☼ balanced in a secure position.

Here's how to saw correctly!

⚠ DANGER! Risk of injury! Always switch the motor off before you put the device down!

- ☼ Search the work area and remove objects which are in your way.
- ☼ When you begin work, check the safety of the device (► Check before starting! – p. 16).
- ☼ Take the device in both hands as instructed.

Risk of kickback!

Kickbacks occur if the upper edge or tip of the saw rail touch wood or other hard objects. The device is thrown with high energy back and forth, which can cause extremely severe injuries.

⚠ DANGER! Risk of injury! When working with the device, dangerous kickbacks may occur! Severe or even fatal injuries can be the result! Before beginning work with the device, the chain brake must be checked to ensure that it is functioning correctly.

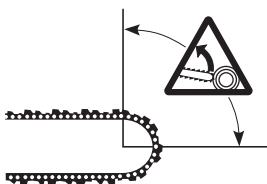

Avoid letting the area of the saw rail depicted on the right touch wood or other hard objects.

In order to reduce the risk of injury in case of a kickback, the device is equipped with a chain brake which is triggered automatically on impact and which stops the saw chain immediately.

For safety reasons, the functionality of the chain brake must be checked each time before the device is used (► Checking the chain brake – p. page 14).

With less strong kickbacks, it can happen that the chain brake is not triggered automatically.

For this reason it is important that the device be held firm with both hands.

Only a careful and correct working method can reduce the risk of a kickback reliably!

Basic work technique

⚠ DANGER! Risk of injury! This section treats the basic work technique when handling the device. The information provided here does not replace the many years of training and experience of a professional. Do not perform any work for which you are not sufficiently qualified! Thoughtless handling of the device can cause severe or even fatal injuries!

Before each use

1. Check the chain brake to ensure it is functioning correctly.
2. Check the rear hand guard for damage.
3. Check the switch-on safety lock and start button to ensure they are functioning correctly.
4. Check whether all handles are free of oil.
5. Check whether all parts of the device are present, firmly attached and undamaged.
6. Check the chain catcher for damage.
7. Check the chain tensioning.

Sawing technique

Pulling sawing

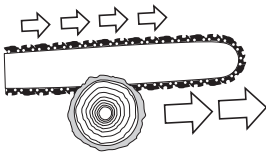

With this technique, sawing occurs with the underside of the saw rail from above downwards. The saw chain thus pushes the device forwards away from the user. This way, the front edge of the device forms a support, which catches the forces which arise on the tree trunk when sawing. With pulling sawing, the user has much more control over the device and can avoid kickbacks better. Therefore, this is the preferred sawing technique.

- ✿ Saw as close to the motor block as possible and allow the claw stop to grip into the wood. This prevents the saw from kicking back out of control.
- ✿ If the claw stop is too firmly caught, pull the handle of the saw upwards. The leveraging effect will push the saw rail down making the sawing work easier.

Pushing sawing

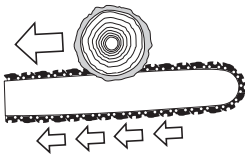

With this technique, sawing occurs with the upper edge of the saw rail from below upwards. The saw chain thus pushes the device backwards towards the user. If the saw rail twists, the device can fly towards the user with great force. The leveraging effect will push the saw rail down making the sawing work easier.

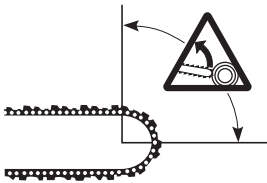

If the user does not balance out the force of the saw chain pushing backwards with his or her bodily force, there is a danger that only the tip of the saw rail will make contact with the wood and there will thus be a kickback (► Risk of kickback! – p.17).

Felling a tree

⚠ DANGER! Risk of injury! Felling and delimiting work may only be performed by trained people! There is a risk of fatal injuries!

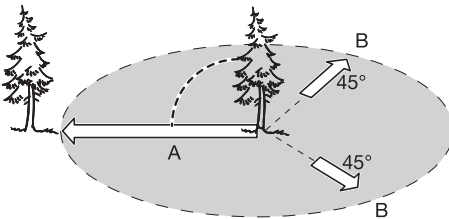

Before beginning the felling work, make sure that:

- ☼ there are no people or animals in the felling area of the tree.
- ☼ there is an obstacle-free escape route for each participant. A retreat occurs diagonally counter to the felling direction.
- ☼ the area around the trunk is free of obstacles (risk of stumbling!).
- ☼ the next workplace is at least two and a half tree lengths away. Before felling, the felling direction of the tree must be checked and it must be ensured that there are no objects, people or animals in a distance of $2\frac{1}{2}$ tree lengths.

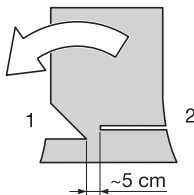

The felling of a tree occurs in two steps:

1. Notch the trunk by approximately one-third of its diameter on the felling direction side.
2. On the other side, make the felling cut, which must be somewhat higher than the felling notch (approx. 5 cm).

⚠ DANGER! Risk of injury! Never saw the tree trunk completely through. The area serves as a "hinge" and ensures a defined felling direction.

⚠ DANGER! Risk of injury! When felling, stand only to the side of the tree to be felled! **There is a risk of fatal injuries!**

Trunks lying flat on the ground

- ✿ Cut into the trunk halfway, then turn over and saw through from the opposite side.

Note: Device damage! Make sure that the saw rail does not touch the ground while you are sawing through the trunk!

Propped-up trunks

We recommend that you place trunks to be sawed through on sawhorses. If this is not possible, the trunk should be lifted with the help of supporting branches and placed over trestles.

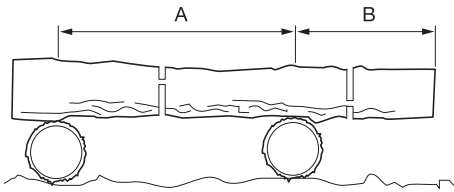

In area A, first cut through approximately one third of the trunk diameter from above downwards, then make the final cut from below upwards. In area B, first cut through approximately one third of the trunk diameter from below upwards, then saw through from above.

⚠ DANGER! Risk of injury! Do not saw any trunks under tension! Splintering wood or a twisted saw rail can cause extremely severe injuries!

⚠ DANGER! Risk of injury! Always place on the higher side of the trunk, as there is a risk that it may roll away.

Removing branches

- ✿ Always work on the side opposite the branch in question.
- ✿ Begin at the bottom of the trunk and work upwards.
- ✿ Always guide the saw from above downwards through the wood.

When removing the branches from trunks which are lying down, first saw off the free branches sticking up in the air. Only saw off supporting branches when the trunk is sawed in lengths

⚠ DANGER! Risk of injury! Branches that are high up or under tension can wedge the saw chain in the wood!

7. CLEANING AND MAINTENANCE

⚠ DANGER! Risk of injury! Before any maintenance or cleaning work:

- ✿ Remove the battery.
- ✿ Let the device cool down.

Cleaning and maintenance overview

After each use

What?	How?
Clean the device	Cleaning the device – p. 21

Annually

What?	How?
Re-tension saw chain	Re-tensioning the saw chain – p. 22
Clean oil guide groove of the saw rail.	Cleaning the oil guide groove of the saw rail – p. 22
Sharpen the saw chain.	Sharpening the saw chain – p. 22

Cleaning

Cleaning the device

- ✿ Remove coarse dirt.
- ✿ Wipe down the device with a slightly damp cloth.

Cleaning the oil guide groove of the saw rail

- ✿ Remove the saw rail.
- ✿ Clean dirt from the oil guide groove of the saw rail with a suitable tool. (plastic spatula, do not use any steel tools!)
- ✿ Replace saw rail (► Assembling the saw rail and saw chain – p. 13).

Re-tensioning the saw chain

► (see Fig. 6)

- ✿ Lift the tip of the saw rail slightly.
- ✿ Tighten the tensioning screw (6) until the chain lies on the underside of the saw rail.

Sharpening the saw chain

Special tools are required to sharpen the saw chain; these guarantee that the cutting of the chain occurs at the correct angle and the correct depth. We recommend that you have the saw chain sharpened by a professional.

Storage and transport

Storage

⚠ DANGER! Risk of injury! Make sure that unauthorized persons do not have access to the device!

- ✿ Let the device cool down before you store it.
- ✿ Store the device as horizontally as possible.

Longer downtimes

If you are not going to be using the device for a while, remove the chain oil from the device. Store the device in a dry place.

Transport

If you are transporting the device in a vehicle:

- ✿ Slip the protective cover onto the cutting tool.
- ✿ Secure the device against slipping.
- ✿ If possible, use the original packaging for dispatching.

Faults and remedial measures

When something isn't working...

⚠ DANGER! Risk of injury! Improperly performed repairs can lead to the device not functioning safely. This endangers yourself and your environment.

Malfunctions are often caused by minor faults. You can easily remedy most of these yourself. Please consult the following table before contacting the vendor. You will save yourself a lot of trouble and possibly money too.

Fault/malfunction	Cause	Remedial measure
Device does not work.	Battery not slotted in correctly?	Slot battery into place.
	Battery pack dead?	Charging the battery pack – page 16.
	Battery pack defective?	Contact your local vendor.
	Is the device defective?	

If you can't fix the fault yourself, contact your nearest vendor. Please be aware that any improper repairs will also invalidate the warranty and additional costs may be incurred

8. STORAGE

If you do not use the saw for a period exceeding 30 days, proceed as follows.

- ✿ Empty the oil container.
- ✿ Remove and clean the guide bar and the chain. Immerse the guide bar and the chain in a paraffin-based or soap-based cleaning bath.
- ✿ Then dry the guide bar and the chain.
- ✿ Place the chain into a container filled with oil. This will prevent it from corroding.
- ✿ Slightly apply oil onto the guide bar.
- ✿ Wipe the chainsaw body with a cloth. When cleaning, use a soft cloth soaked in a soap water.
- ✿ Store the chainsaw
 - in higher racks or in locked premises out of the reach of children
 - in a dry place

9. TECHNICAL DATA

Rated voltage	20V
Chain speed	7m/s
Cutting length	12"
Battery Pack	Lithium Ion - 4000mA

10. DISPOSAL



The machine, rechargeable batteries, accessories and packaging should be sorted for environmental friendly recycling.

Do not dispose of power tools and batteries/rechargeable batteries into household waste!

