

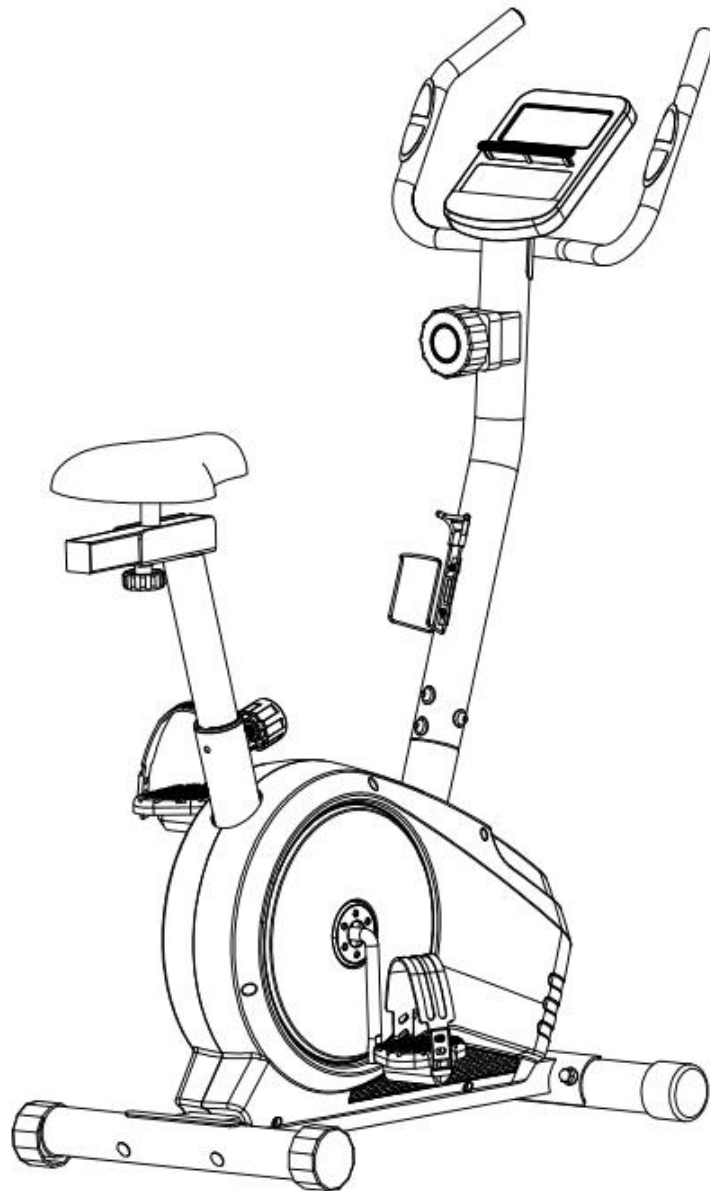

074725 BODYGO FITNESS MAGNETIC UPRIGHT EXERCISE BIKE USER MANUAL



IMPORTANT !

Please read all instructions carefully before using this product.

Retain this manual for future reference.

The specifications of this product may vary slightly from the illustrations and are subject to change without notice.

EXPLODED DIAGRAM

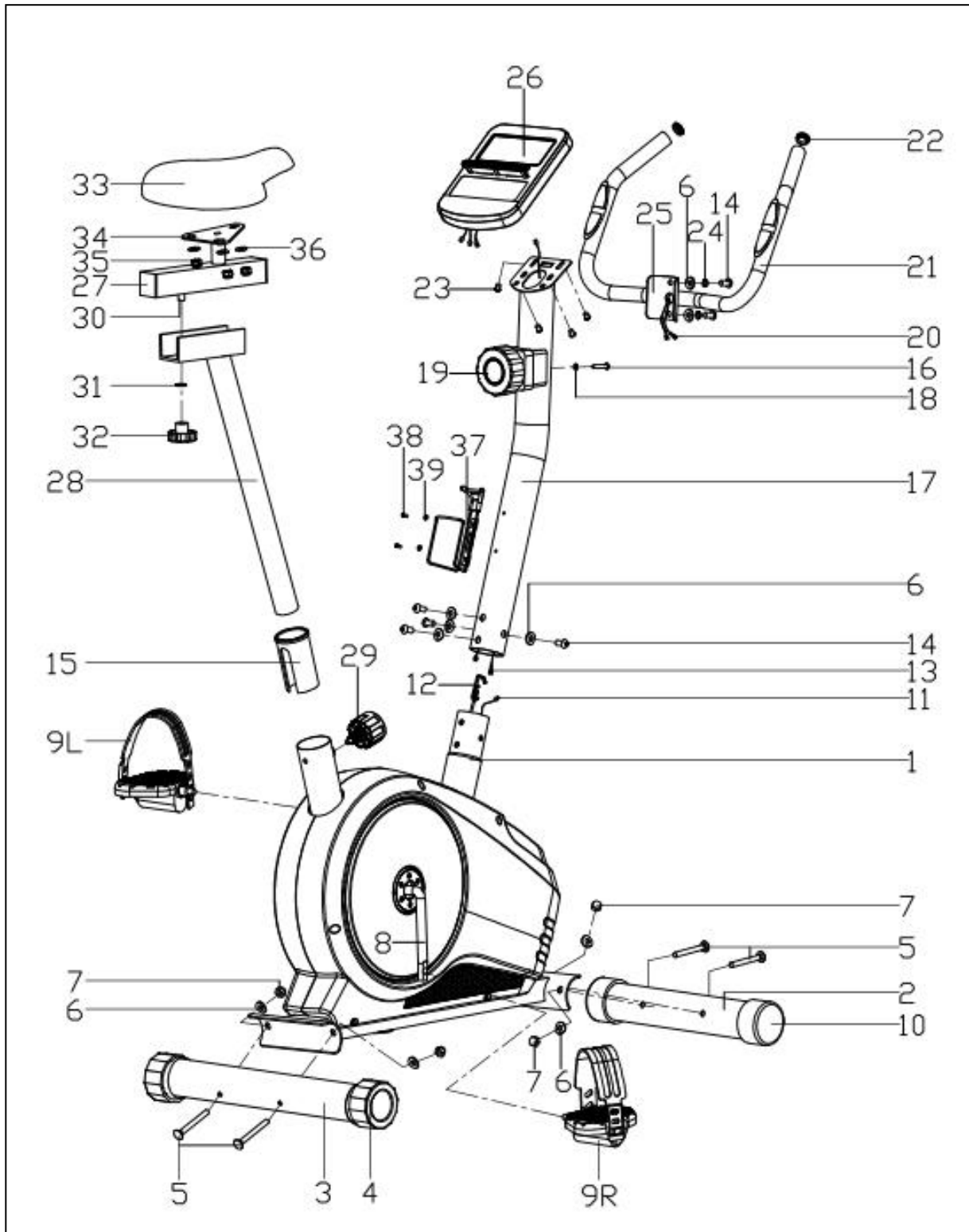

PARTS LIST

NO.	DESCRIPTION	Q'TY	NO.	DESCRIPTION	Q'TY
1	Main frame	1	21	Foam grip	2
2	Front Stabilizer	1	22	Round end cap	2
3	Rear Stabilizer	1	23	Cross pan head screw	4
4	Rear End Cap	2	24	Spring Washer D8x1.5	2
5	Carriage bolt M8×L74	4	25	Handlebar	1
6	Arc WasherΦ8.5x1.5xΦ25xR33	10	26	Computer	1
7	Acorn nut M8	4	27	Square End Cap	2
8	Crank	1	28	Saddle Post	1
9L/R	Pedal	1pr.	29	Knob	1
10	Front End Cap	2	30	U-shaped Slider	1
11	Sensor wire	1	31	Flat Washer D10	1
12	Tension Cable	1	32	Plum-nut	1
13	Extension Wire	1	33	Saddle	1
14	Inner hex bolt M8×16	6	34	Horizontal Saddle Post	1
15	Saddle bushing	1	35	Flat washer D8	3
16	Cross pan head screw	1	36	Nylon nut M8	3
17	Handlebar Post	1	37	Bottle holder	1
18	Arc Washer	1	38	Cross pan head screw	2
19	Tension controller	1	39	Flat washer	2
20	Pulse wire	2			

NOTE:

Most of the listed assembly hardware has been packaged separately, but some hardware items have been preinstalled in the identified assembly parts. In these instances, simply remove and reinstall the hardware as assembly is required.

Please reference the individual assembly steps and make note of all preinstalled hardware.

PREPARATION: Before assembling, make sure that you will have enough space around the item; Use the present tooling for assembling; Before assembling please check whether all needed parts are available.

It is strongly recommended this machine to be assembled by two or more people to avoid possible injury.

The maximum user's weight is 120kg.

ASSEMBLY INSTRUCTION

STEP 1

Attach the front stabilizer (2) and rear stabilizer (3) to the main frame (1) with the carriage bolts (5), arc washers (6) and acorn nuts (7) as shown.

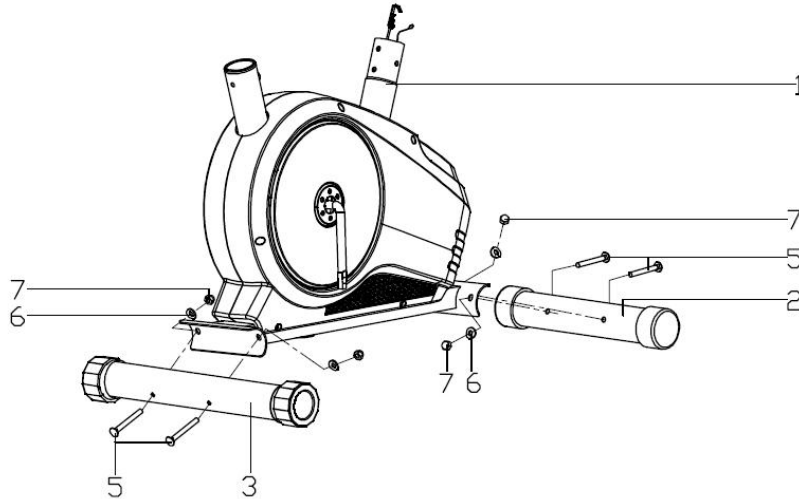

STEP 2

Attach the right and left pedals (9L/R) to the crank (8) respectively.

Important:

Both pedals are labeled, L FOR LEFT and R FOR RIGHT.

To tighten , turn the left pedal COUNTERCLOCKWISE and the right pedal CLOCKWISE.

★ Always keep the left and right pedal completely tightened when using the bike. Failing to follow the instructions may cause damage to the thread of the pedals.

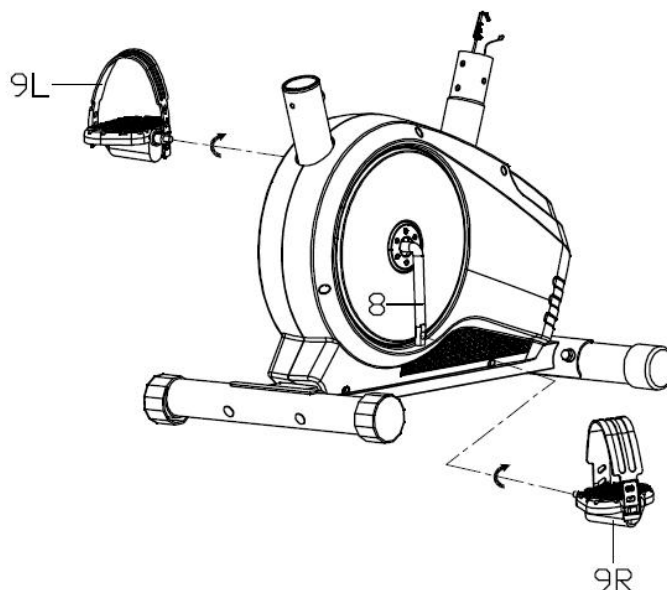

STEP 3

Attach the saddle (33) to the horizontal saddle post (34), and then attach the horizontal saddle post (34) to the saddle post (28) with the flat washer (31) and plum-nut (32) as shown.

At last, insert the saddle post (28) into the main frame (1) and fix with the knob (29) at a proper height as shown.

★ Always make sure the saddle has been tightly fastened on the horizontal saddle post before your movement.

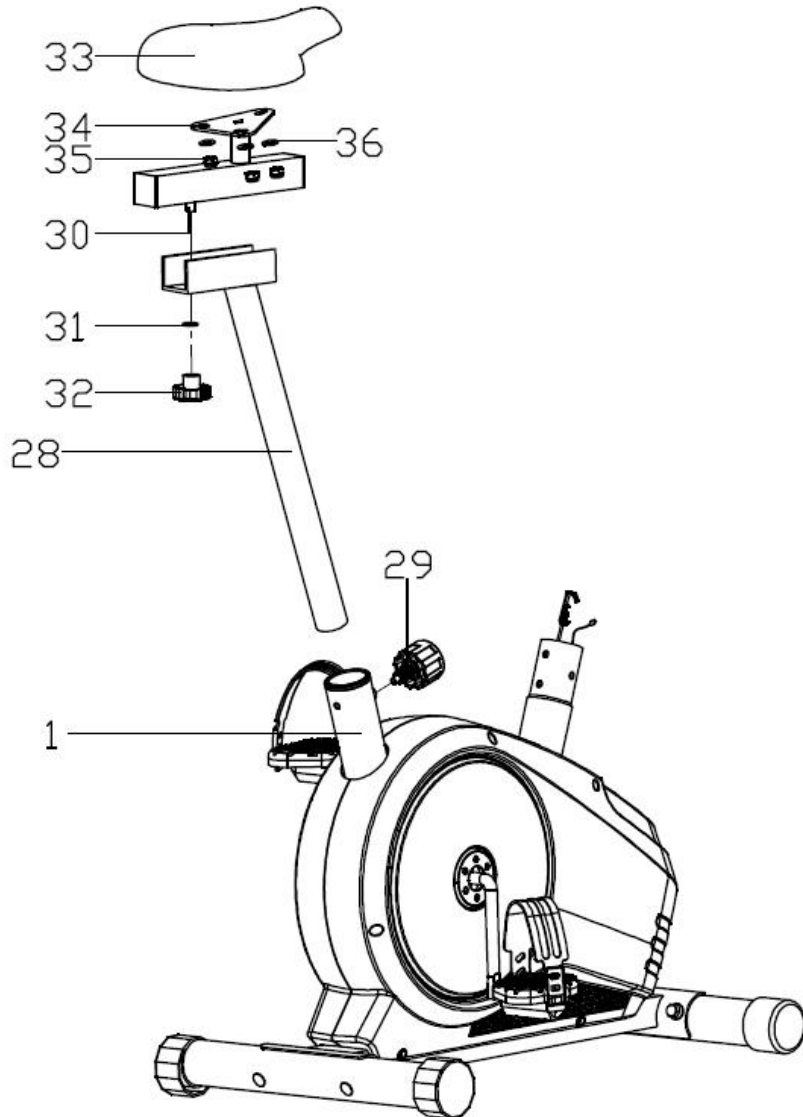

STEP 4

A: Connect the extension wire (13) with the sensor wire (11).

B: Put the cable of tension controller (19) into the spring hook of tension cable (12) as picture A shows. Then pull the resistance cable of tension controller (19) upward and force it into the gap of metal bracket of the tension cable (12).

C: After making sure the wires are well connected, then fix the handlebar post (17) to the post of main frame (1) with the inner hex bolts (14) and arc washers (6).

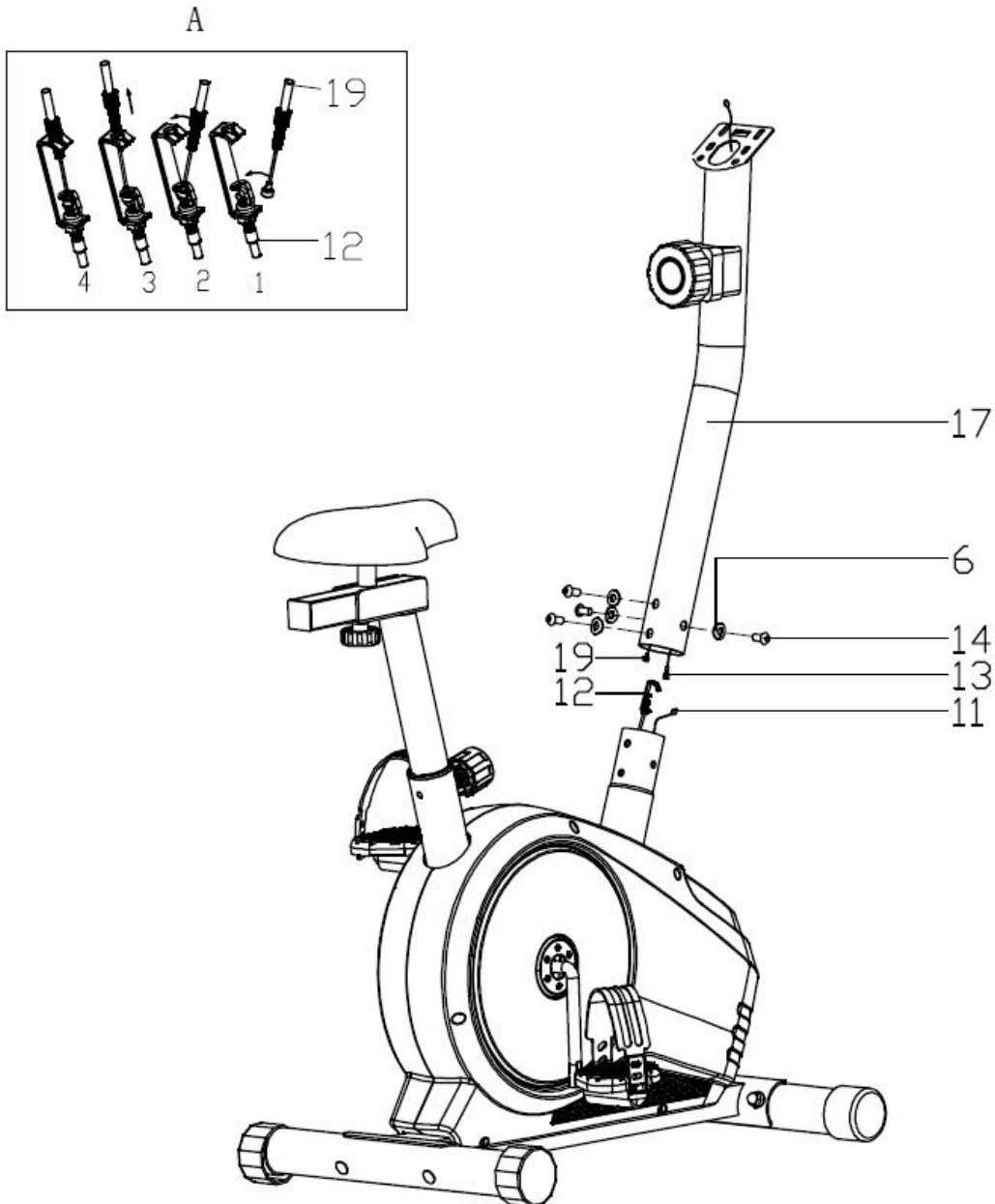

STEP 5

A: Insert the pulse wires (20) through the hole on the handlebar post (17) and pull them out from the top of the computer bracket.

B: Attach the handlebar (25) to the handlebar post (17) with the inner hex bolt (14), spring washer (24), and arc washers (6).

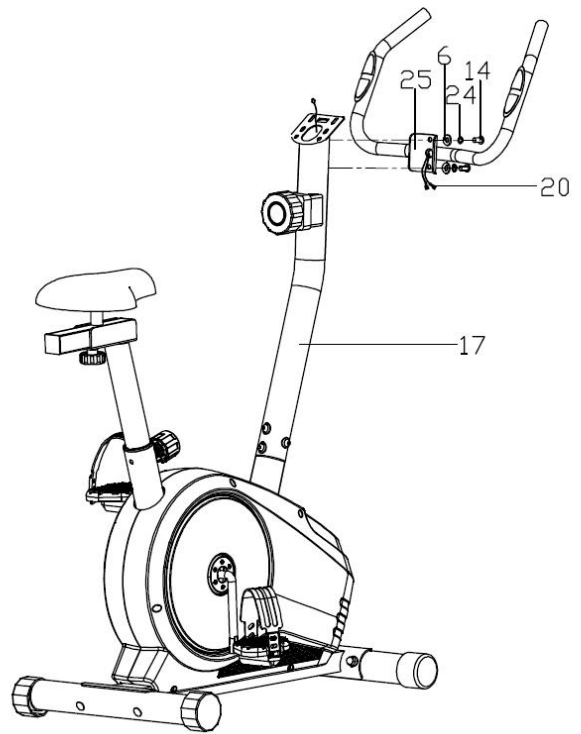

STEP 6

A: Connect the pulse wires (20) and extension wire (13) to the wires coming out from the computer (26) respectively. Then attach the computer (26) onto the bracket of handlebar post (17) tightly with the cross pan head screw (23) as shown.

B : Attach the Bottle holder (37) to the handlebar post (17) with Cross pan head screw (38) and Flat washer (39).

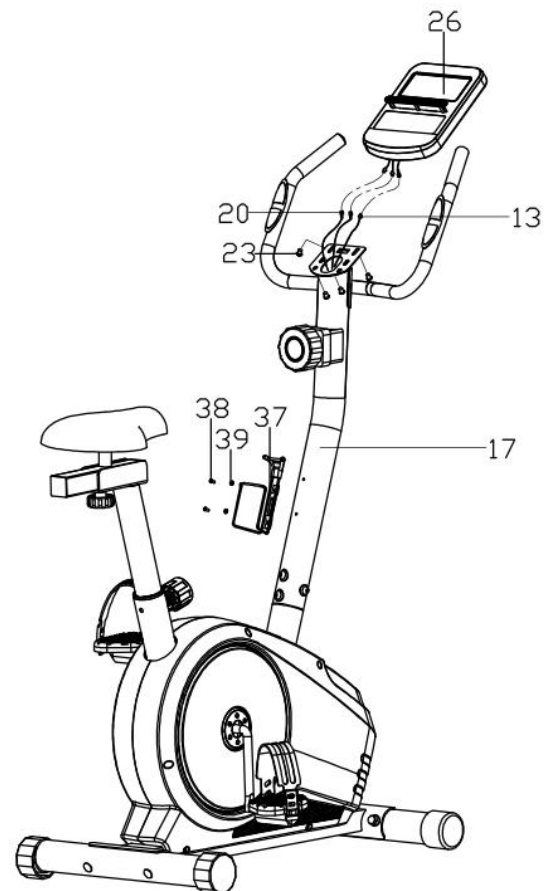

USING YOUR BIKE

Using your bike will provide you with several benefits. It will improve your physical fitness, tone your muscles and in conjunction with a calorie controlled diet, help you lose weight.

WARM-UP PHASE

The purpose of warming up is to prepare your body for exercise and to minimize injuries. Warm up for two to five minutes before strength-training or aerobic exercising. Perform activities that raise your heart rate and warm the working muscles. Activities may include brisk walking, jogging, jumping jacks, jump rope, and running in place.

STRETCHING

Stretching while your muscles are warm after a proper warm-up and again after your strength or aerobic training session is very important. Muscles stretch more easily at these times because of their elevated temperature, which greatly reduces the risk of injury. Stretches should be held for 15 to 30 seconds.

DO NOT BOUNCE.

Remember always to check with your physician before starting any exercise program.

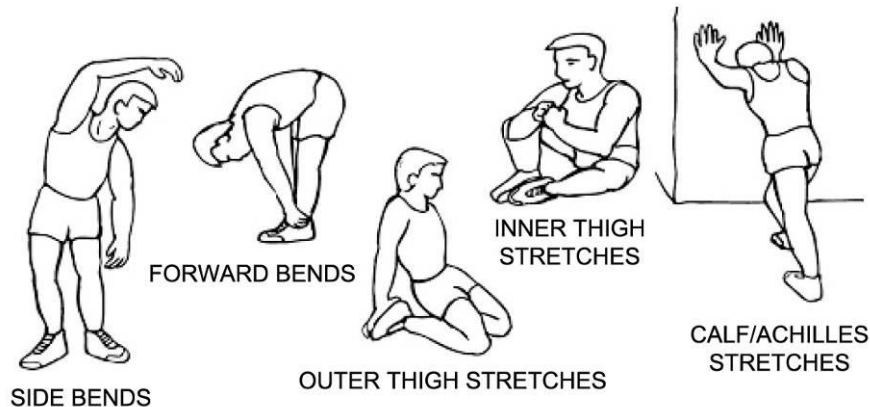

EXERCISE PHASE

This is the stage where you put the effort in. After regular use, the muscles in your legs will become more flexible. Work at your own pace and be sure to maintain a steady tempo throughout. The rate of work should be sufficient to raise your heartbeat into the target zone shown on the graph below.

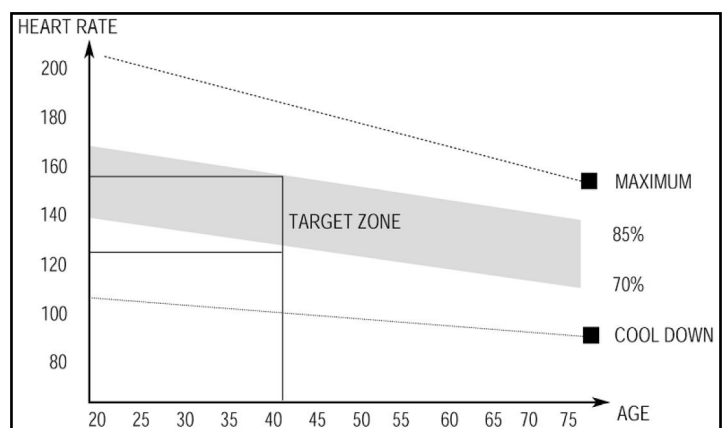

COOL-DOWN PHASE

The purpose of cooling down is to return the body to its normal or near normal, resting state at the end of each exercise session. A proper cool-down slowly lowers your heart rate and allows blood to return to the heart.

YK-YB1904 EXERCISE MONITOR INSTRUCTION

DISPLAY INFORMATION

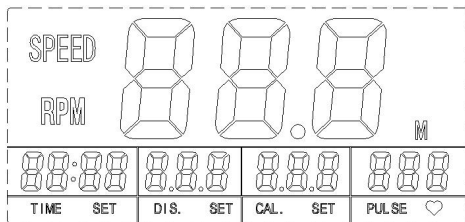

- 1) Main display area: SPEED/RPM;
- 2) TIME, DISTANCE, CALORIE, PULSE display area;

KEY FUNCTION

MODE	. START Status: Changeover display SPEED or RPM; . STOP Status: Enter the setting mode, and choose set items needs to be set
SET	. In setting mode, adjusted the value of TIME、DISTANCE、CALORIE;
RESET	. In setting mode, the value clear;

INSTRUCTION:

1. START Status:

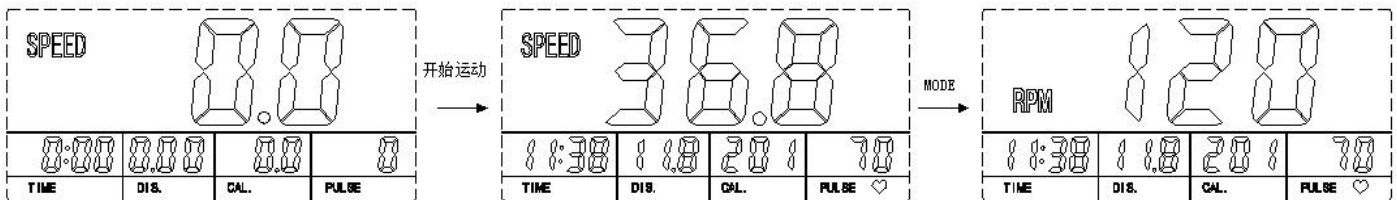

2. Motion Status:

- 1) Press MODE key to choose setting items with relevant flashing for TIME, DISANCE, CALORIE;
- 2) Press SET key to adjusted;
- 3) If any of these are setting, The corresponding value will be inverted in motion status. When any of setting value count to 0, the motion will be "DI DI" Voice Prompt;

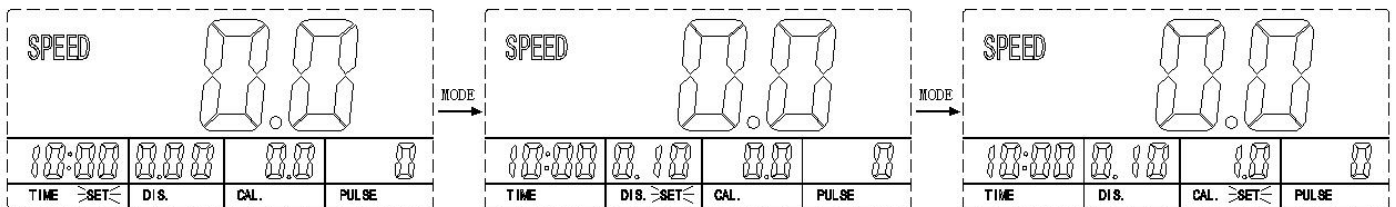

WIRELESS PLUSE (Optional)

Supports the standard 5.3Khz wearing heart rate detector;

SPECIFICATION

TIME.	. 0M:00S ~ 99M:00S
SPEED	. 0.00 ~ 99.9KM/H
DISTANCE	. 0.0 ~ 999KM
CALORIES	. 0.0~ 999KCAL
PULSE	. 40-240BPM
RPM	. 0 ~ 999RPM
Battery Type	Size-AAA or UM-4
Operating Temperature	0°C ~ +40°C
Storage Temperature	-10°C ~ +60°C

Importer:
Ogalas ULC
Unit 4 Parkway House
Ballymount Drive
Dublin
D12 ECR9